



Stack Emissions Testing General Method Statement

CAT-GMS

(VERSION K)

Authorised By:

James Harmer
Technical Manager

Contact Details

<p>Stockport (CST) Office & Head Office (CHO) Unit C6 Emery Court The Embankment Business Park Heaton Mersey Stockport SK4 3GL T: 0161 432 3286 F: 0161 432 3689</p> <p>General Manager – Environmental Division: Alastair Wolff (CHO) M: 07886 533 130 E: alastair.wolff@exova.com</p> <p>Regional Manager: Toby Campbell (CST) T: 07825 130 074 E: toby.campbell@exova.com</p>	<p>Swindon (CSW) Office Unit 11 Aspen Close Swindon SN2 8AJ T: 01793 497 902</p> <p>Regional Manager: Stuart Davidson T: 07957 554 956 E: stuart.davidson@exova.com</p>	<p>Glasgow (CEK) Office 70 Montrose Avenue Hillington Park Glasgow G52 4LA T: 0141 941 2022</p> <p>General Manager: Barry Grant T: 07826 916 683 E: barry.grant@exova.com</p> <p>Regional Manager: John Healey T: 07826 916 681 E: john.healey@exova.com</p>	<p>Dublin (CDU) Office Unit 18 Tallaght Business Centre Whitestown Business Park Dublin 24 T1: +353 (0) 86 8538247 T2: 07826 916 683</p> <p>Regional Manager: Nicholas Kenny M: +353 (0) 86 8538247 E: nick.kenny@exova.com</p>
--	---	---	--

<p>Rotherham (CRO) Office Unit C22 Century Park Network Centre Dearne Lane Rotherham S63 5DE T: 0161 432 3286 F: 0161 432 3689</p> <p>Regional Manager: Toby Campbell T: 07825 130 074 E: toby.campbell@exova.com</p>	<p>Caerphilly (CCA) Office Unit 37 Evans Business Centre Western Industrial Estate Caerphilly CF83 1BE T: 01793 497 902 F: 01793 430 533</p> <p>Regional Manager: Stuart Davidson T: 07957 554 956 E: stuart.davidson@exova.com</p>	<p>Newcastle (CNE) Office Shields Road Newcastle upon Tyne NE6 2YD T: 07826 916 683 F: 01355 249 083</p> <p>Regional Manager: John Healey T: 07826 916 681 E: john.healey@exova.com</p>	<p>Luton (CSE) Office Unit 10 Greenwood court Ramridge Road Luton LU2 0TN T: 01582 729222</p> <p>Regional Manager: Stuart Davidson T: 07957 554 956 E: stuart.davidson@exova.com</p>
---	---	---	--

Introduction

This method statement is designed to highlight the general principles which Exova Catalyst's (Catalyst) employees work to, when performing UKAS and MCERTS accredited stack emissions testing at client's sites. Purple text indicates a hyperlink. Clicking on a hyperlink will jump to the relevant detail in the Appendix, at the back of this document, or to a document available on the internet.

Staff Competency

All Exova Catalyst Staff receive training on both the technical and health & safety aspects of stack emissions testing. All staff hold a CCNSG Safety Passport (or Safe Pass in Ireland), have attended a 'Hazard Identification and Risk Assessment Relating to Stack Emission Monitoring' course, are trained in the use of rope kits & safe manual handling and are trained first aiders. Lone working is rarely utilised, however when it is required, it is only performed by an experienced member of staff who telephones a "buddy" at regular intervals.

Pre-Test Requirements

SAMPLING PLATFORM

[See [APPENDIX 1: Sample Platform Requirements](#) & [APPENDIX 3: Diagrams](#)]

- There are many hazards associated with stack emissions testing, as it invariably involves working on industrial sites, at height, in inclement weather conditions and using a variety of equipment. Exova Catalyst takes the health & safety of its employees extremely seriously. Therefore, stack emissions testing may only be performed from platforms that meet the stringent requirements of the Environment Agency and the Source Testing Association (STA). In addition to permanent platforms and scaffold structures, it may be feasible to perform testing from MEWPs (cherry pickers / scissor lifts) or mobile scaffold towers, however this will depend upon the type of testing to be employed, and will only be deemed acceptable after taking a risk management approach to the platform type selection process. Typically, MEWPs are acceptable where minimal equipment is required to be inserted into the stack for the duration of the testing. Such instances will include velocity traverses, testing for combustion gases and total VOCs where just a heated probe is required to be installed into the stack, or where Speciated VOCs sampling is performed with sample tubes and a small sampling probe.
- Working platforms (including scaffolding and roofs) should be regularly inspected by a competent person for any signs of structural deterioration (it should have an inspection certificate – see STA Guidance Note: [WAH 0001 Inspection of Permanent Elevated Working Platforms](#)).
- Scaffold structures must be built to safely support the expected weight of the testing equipment and personnel. General duty scaffolding (Point Load: 200 kg/m³) will normally suffice as heavy sampling equipment is normally left at the base of the stack with umbilicals and heated lines sent up to the stack

sampling ports. However, where it will be required to have the heavy sampling equipment positioned on the scaffold platform itself, heavy duty scaffolding (Point Load: 300 kg/m³) may be required.

- Ladders (including stepladders) must not be used as a working platform to perform stack emissions testing from.
- Stepladders may only be used to access sampling ports that cannot be easily reached from ground level (approximate guideline would be feet no higher than 0.5m from ground level) where the work is low risk, short duration (< 30 mins) and there is no other suitable means of access.
- Mobile stepladders with handrails & platform (e.g. podium steps) may be used to access higher sampling ports (approximate guideline would be feet no higher than 1.5m from ground level) where the work is low risk, short duration (< 30 mins) and there is no other suitable means of access
- Your Exova Catalyst contact will discuss the most suitable form of access to the stack and sampling ports if a permanent sampling platform is not available.

ACCESS PORTS

[See [APPENDIX 2: Access Port Requirements](#) & [APPENDIX 3: Diagrams](#)]

- In order to perform stack emissions testing, it is necessary for the testing team to be able to insert their equipment into the stack. The easiest and safest way of doing this is through dedicated access ports which are welded to the stack. The number of access ports required will depend on the shape (circular / square) and cross-sectional area of the stack in question. The operator should ensure that all access ports are “loosened” prior to the emissions testing team’s arrival on-site.

POWER & LIGHTING

- Stack emissions testing equipment requires access to 110V power (either directly or via a 240V supply and 110V step down transformer). Ideally this should be available at both the top and bottom of the sampling platform, although extensions cables will be used if necessary. (4 x 240V / 6 x 110V supplies is normally sufficient for the most demanding emissions testing campaigns, although a reduced number of supplies may suffice for less demanding campaigns)
- If it is anticipated that that testing will be carried out in the dark (i.e. short days during the winter months), lighting of the test area must be adequate to ensure the work can be carried out. Exova Catalyst will provide auxiliary lighting where necessary.

Prior to Arrival on Site

A Site Review (CAT-SR) and Site Specific Protocol (CAT-SSP) will be generated before arrival on site. The SSP must be agreed to, and signed off, by the site contact before any sampling may commence, as it includes details on how the job will be performed, including the types, number and duration of tests; the methods to be used and any deviations from the methods that will need to be implemented; emission limit and expected emission values; and platform / sampling location specific information.

Arrival On Site

On arrival, the sampling team will sign in at the gate house / main reception and will then report to the site contact. Inductions will be followed and any Permits to Work will be signed onto. Before going to the sampling location/s, PPE will be worn which, as a minimum, will consist of Safety Boots, Hard Hat, Gloves and Eye Protection. Other PPE will be worn as required by either the site rules or appropriate for the situation.

Getting to the Sampling Location

As stack emissions testing necessitates transporting a large amount of heavy equipment, it will more than likely be necessary to drive as close as possible to the sampling location. Where this is the case, site speed limits and one-way systems will be adhered to at all times. Upon arrival at the closest possible point to the sampling location, the vehicle will be parked in a courteous manner and so as not to cause obstruction to any other road users.

Pre-Work Risk Assessment and Platform Inspection

Before ascending any stairs / ladders to the sampling location, a Risk Assessment (CAT-RA) will be completed, identifying areas of low, medium and high risk. This considers hazards associated with the job including noise, weather conditions, exposure to stack gas, manual handling etc. The findings of the risk assessment will be communicated to every member of the sampling team, and any high level risks will be communicated to the site contact, who will work with the sampling team to reduce the risk classification to either low or medium. Where further control measures are identified, these must be put in place before any work commences. If possible, the site contact should sign the Risk Assessment to agree to its findings.

If a permanent working platform is to be used, a platform inspection certificate will be requested of the site contact. If one is not available, the emissions testing team leader will make an assessment of the general condition of the platform through a visual and tactile pre-use inspection, although he will not be a trained structural engineer. **Under The Work at Height Regulations 2005, it is the responsibility of the operator to provide a safe working platform to all personnel working at height. Operators are therefore encouraged to carry out regular inspections on their platforms to ensure they are safe and fit for purpose.** This inspection may

be performed by a suitably qualified member of staff on the site, or an external inspection company may be called upon. Speak to your Exova Catalyst contact for further information on where to find a suitable platform inspection company.

If a scaffold structure is to be used, as part of the Risk Assessment, the emissions testing engineer will check that a Scafftag™ (or similar inspection record) is present, and that it meets the Point Load requirements of the testing to be employed.

At the Sampling Location

Equipment will be unloaded from the vehicle and where working at height is required, Men Working Overhead signs will be erected and the work area will be cordoned off using barrier tape. The equipment will then either be assembled at the base of the stack, or carried / hauled to the sampling platform. Exova Catalyst utilise lifting equipment including a rope, karabiners and pulley system, which is designed to minimise manual handling injuries associated with lifting and also reduce the risk of equipment falling during the lifting exercise. This usually requires one person at the base of the lift, pulling the kit using the rope and pulley, and the other at the sample platform lifting the kit over the hand rails once it has been pulled up. In order to minimise manual handling as much of the heavy items of kit as possible will be left at ground level, with heated lines and umbilicals utilised to connect these items to those on the sampling platform.

Once in position, the equipment will be plugged into 110V power supplies and switched on. The number of supplies required will depend on the type and number of instruments being used. All trailing leads will be assessed for the potential to cause trip hazards, and will be tidied accordingly. Some kit will require up to 60 minutes warm-up time, before testing may begin. During this time, the access ports will be carefully removed to minimise the chances of dropping them to the ground below the platform. High positive pressure stacks will be approached with caution to prevent exposure to stack gases. Where there is a danger of exposure, the flow of positive pressure will be restricted by sealing around sampling ports during sampling. In addition, the sampled gas may be vented back into the duct where practicable or away from personnel. A suitable protective mask may also be worn. Hot stacks will also be approached with caution, with heat resistant gauntlets being worn to reduce the chances of burns occurring when handling the access ports or probes that have been exposed to the hot stack gas.

After gaining access to the stack, the next step will be to perform a stack velocity and temperature traverse, using a Pitot Tube and Thermocouple. Combustion processes may also require a further gaseous pollutant traverse (using a suitable analyser) to check that the stack gas is well mixed and therefore classed as being “Homogenous”. This traverse may also be used to identify whether single point or multi-point sampling is required for certain

tests. Air either entering or escaping from the sampling ports will be minimised by using probe clamps which will seal the ports, for the duration of these checks.

Once the equipment warm up period has elapsed, analysers will be run through their pre-use check and calibration procedures. If required, heated sample lines, probes and ovens will be brought up to temperature. Staff will wear suitable heat resistant gloves when handling hot pieces of equipment.

Where samples are taken via impingement through chemical solutions (e.g. heavy metals, mercury, hydrogen fluoride etc.), emissions testing engineers will wear suitable chemical resistant gloves, in addition to their standard PPE, when handling the impingers and the chemicals which go into them. The volumes of chemicals used on site are very small, but any significant spillages will be reported to the site contact. All unused or waste chemicals will be taken away from site and disposed of by the correct means back at the base laboratory. Chemical risk (COSHH) assessments and Material Safety Data Sheets are available to view at any point during the testing team's time on site.

Where gas cylinders are required for analyser calibration, the ADR Regulations (2009) will be fully complied with. If it is a requirement that the cylinders are needed at the sampling location (i.e. lifted to a platform), they will be lifted using a dedicated lifting bag, with a Safe Working Load (SWL) well in excess of the weight of the cylinder. Gas cylinders will be stored safely in cylinder racks to prevent them from being knocked over.

Weather conditions play an important factor in stack emissions testing, and it will always be preferable to set up equipment (and even test) inside a Plant building. If this is not possible, the emissions testing team will invariably either find a sheltered place, or set up a tarpaulin or temporary shelter to protect both themselves and the equipment from the weather. Specific care will be taken when working on hot days, with sun screen and bottled water provided to all members of staff to reduce the likelihood of sunburn and sunstroke.

A typical working day will consist of 8 to 10 hours (including travel to and from site). However, from time to time, longer days may be required. In this case it will be the responsibility of the emissions testing Team Leader to decide how many hours the team can work before tiredness may increase the risk of accidents occurring. Regular breaks are actively encouraged by the Exova Catalyst Management team, especially after periods of high exertion (such as lifting / carrying heavy equipment up to the sampling location).

At the End of Sampling

Where samples need to be recovered, this recovery will take place in a clean and dry location. This may either be in the back of the vehicle, or in a clean room on site. Staff performing the recovery procedure will wear

appropriate PPE. If no clean location is available on site, the impingers and sample liners will be capped and transported back to the base laboratory for sample recovery.

Back at the sampling location, access fittings such as sample port caps or flange plates will be replaced securely.

Note: If sample port caps cannot be replaced securely (e.g. due to worn or corroded fittings) then they will be left off and the site contact will be informed before the sampling team leave site – this is to reduce the risk of the port caps falling off after the sampling has been completed. All equipment will be shut-down, following their respective shut-down procedures. Power cables will be disconnected and tidied away. All the equipment on the sampling platform will be safely lowered / carried down, using the same techniques that were originally used to get the equipment onto the sampling platform. The platform and any surrounding areas will be checked for tidiness, and any rubbish will be removed.

The sampling equipment will then be loaded back into the vehicle and any Permits to Work will be signed off. The site contact will be found and informed of how the sampling campaign went, and any questions answered. As the emissions testing team leave site, they will sign out at the place they originally signed in at.

Emergency Response Procedure

In the unlikely event of an emergency / accident which means that one of the stack emissions testing engineers falls ill, badly injures themselves, becomes overcome with stack gases etc., either on an elevated platform meaning they are not able to get themselves down to ground level, or any other place on the client's site, the other member of the team will first make the area safe, by either removing the danger, or removing all staff from the area, followed by putting the incapacitated engineer in the recovery position (where applicable), before raising the alarm with the site. This raising of the alarm can be by any means necessary (shouting for help, calling a phone number or physically raising the alarm by leaving the sampling platform / location and finding someone, an emergency telephone etc.). There may be site specific information in inductions which should also be followed when deciding how best to raise the alarm.

If necessary, the emergency services will be called (dial 999 from any phone) to assist either from a medical point of view (ambulance), or to aid in getting the incapacitated engineer down from the elevated platform (fire service). Where emergency services are called, it is imperative that clear directions are given and ideally someone should be waiting to meet them at the site gates to direct them to the emergency.

Where it is safe to do so, no-one in an injured state will be left on their own, so after the alarm has been raised, the person who raised the alarm will return to the casualty, so long as they are sure that "help" is on its way, and the "help" knows exactly where to go.

Back at the Base Laboratory

Where sample recovery was not performed on site, this will take place back at the base laboratory. Appropriate PPE will be worn (chemical resistant gloves, eye protection and lab coat). General waste generated on site will be discarded of in the general waste bins. Any unused reagents will be either returned to the analysis laboratory, or taken via a specialist waste contractor, for proper waste disposal. All equipment will be cleaned (if necessary) and then returned to its place on the shelving racks. Gas cylinders will be securely stored in the gas cylinder storage area of the workshop, well away from any sources of ignition. Any samples requiring analysis will be safely packaged and sent with their chain of custody form to the analysis laboratory/s.

All electronic datasheets, risk assessments, data and photos generated during the site work will be uploaded, into a customer and job number specific folder, onto Catalyst's secure web server to safely store all site data. Once analysis results are received, these will also be saved onto the secure web server so that all job related information is saved into a single place, to enable easy access to all data.

The report will be generated and emailed to the customer within the timescales agreed. Hard copies will be made available on request. The report will, again, be saved onto the secure web server.

End of Method Statement

APPENDIX 1: Sample Platform Requirements

The following summarised information is taken from the Environment Agency's Technical Guidance Note M1 (Monitoring) and BS EN 15259. Click [here](#) to see TGN M1.

The sampling location chosen for the measurement devices and sampling shall be of sufficient size, easily passable, have regards for the safety of personnel (i.e. stack gas should really be under negative pressure) and made in such a way that an emission measurement is representative for the measurement task and is as technically perfect is possible. Installing the platform within the plant building should be investigated.

A risk management approach to stack emissions testing must be taken which means that any sampling platform used must have an adequate weight bearing capacity for the testing to be employed.

Platforms should adhere to the following requirements:

- a) Sufficient working area to manipulate probe and operate measuring instruments.
 NOTE: A sufficient depth of the working area is given by the internal diameter or depth of duct and the wall thickness plus 1.5m, although this will only apply where isokinetic sampling is required e.g. Total Particulate Matter, Heavy Metals, Dioxins/PCBs/PAHs etc. It may be that a reduced depth is sufficient to perform the testing. The suitability of the platform on a site will be confirmed by your Catalyst contact.
- b) Permanent and temporary working platforms must have a load bearing capacity sufficient to fulfil the measurement objective.
- c) At least two handrails, at approx. 0.5m and 1m. Handrails should not obstruct insertion of sample equipment into stack.
- d) Vertical base boards (kickboards) with height of approx. 0.25m.
- e) Removable chains / self closing gates at the top of access ladders.
- f) Designed to allow free flow of water off the platform, and not allow the accumulation of dust.
- g) For large horizontal ducts, a dual level platform may be required to allow safe access to all sample lines.
- h) The area should be well ventilated with artificial lights in place for night time / winter working.

Other provisions of use are:

- a) At least 2 x 110V power supply on the sample platform, with further power supplies at the base of the platform. If outside, these should be protected from rain.
- b) A hoist installed / or stairs to allow easy lifting of sampling equipment up to the sampling platform.
- c) Weather protection (care should be taken on high stacks where weather protection may act as a wind trap, which would put extra stress on the sample platform).

APPENDIX 2: Access Port Requirements (page 1 of 2)

The following summarised information is taken from the Environment Agency's Technical Guidance Note M1 (Monitoring) and BS EN 15259. Click [here](#) to see TGN M1.

Access ports should have a minimum diameter of 125mm (this means using 125mm flange sample ports, although in practice, 4" BSP ports are sufficient to enable easy insertion of sampling equipment). Depending on the type of sampling to be employed, 50mm (or 2" BSP) diameter ports may be installed, however, check the suitability of this reduced size with your Catalyst contact before installing them on your stack.

The number and positioning of these access ports is critical to obtaining reliable test data.

1. Where to position the sample ports

It is important to install the sample ports in a section of waste gas duct where homogenous flow conditions and concentrations can be expected. The requirement for homogenous flow conditions are generally fulfilled if the measurement plane is:

- i. as far downstream and upstream from any disturbance which could produce a change in direction of flow (e.g. disturbances caused by bends, fans or partially closed dampers).
- ii. in a section of duct with at least five hydraulic diameters of straight duct upstream of the sampling plane and two hydraulic diameters downstream (five hydraulic diameters from the top of the stack), and
- iii. in a section of duct with constant shape and cross-sectional area.

It is preferable to select a vertical section, as opposed to a horizontal section of duct as sedimentation of total particulate matter can occur where high total particulate matter concentrations are present in the duct.

2. Correct installation of sample ports

The sample ports should be installed at a height of between 1.2 to 1.5m from the floor of the platform (i.e. between waist and chest height). It is important to ensure that nothing blocks access to the sample port and the space behind it. All ports should be installed in such a way which will enable them to be safely accessed (i.e. no requirement to lean over the edge of the platform, equipment not suspended above a vertical drop). If ports are installed in such a way which would mean that the stack testing engineer would have to act in an unsafe manner, that sample port will not be utilised.

APPENDIX 2: Access Port Requirements (page 2 of 2)

3. Selecting the correct number of sample ports

The table, below, should be used to calculate the correct number of sample ports to install on the stack, taking into account stack diameter (for circular stacks) and stack cross-sectional area (for square / rectangular stacks).

CIRCULAR STACK		SQUARE / RECTANGULAR STACK (CEN)		SQUARE / RECTANGULAR STACK (ISO) ¹	
Range of Duct Diameters (m)	Min. Number of Sampling Lines	Range of Sampling Plane Areas (m ²)	Min. Number of Sampling Lines	Range of Sampling Plane Areas (m ²)	Min. Number of Sampling Lines
< 0.35	1 ²	< 0.1	1	< 0.09	1
> 0.35 to 2.0	2	0.1 to 1.0	2	0.09 to 0.38	2
> 3.6	4 ³	1.1 to 2.0	3	0.38 to 1.5	3
		> 2.0	≥ 3	> 1.5	4

¹ Speak to your Catalyst contact to find out whether any of your tests will need the ISO sample port requirements (e.g. BS ISO 9096).

² Although a single access port may be used, space permitting, it is preferable that 2 should be installed.

³ If space permits, it is desirable to install 4 sample ports (at 90° to each other on large, vertical circular stacks)

4. Port Positioning

Circular Stacks - ports should be positioned at 90° to one another, at exactly the same height.

Square / Rectangular Stacks - ports should be equally spaced and comply with the minimum number of side divisions as specified in the table, above. To calculate the position of each port, divide the length of the side on which the sample ports will be installed, by the number of sample lines required. Split the cross-section of the stack into equally sized boxes, based upon this generated number. The centre line of each sample port should be in line with the centre point of each of these equally sized boxes. **Ports should always be positioned on the longer side of the duct.**

Square / Near Square Ducts

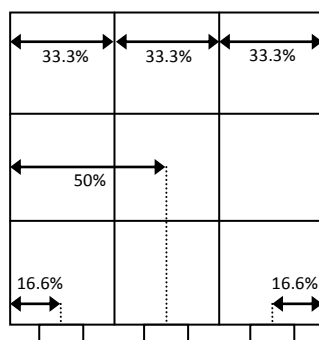

Rectangular Ducts

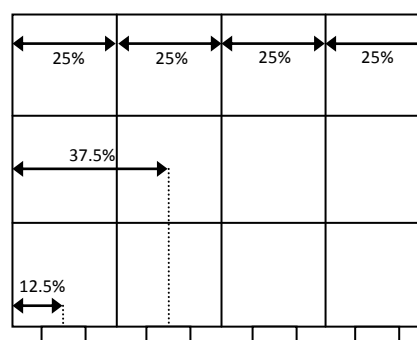

APPENDIX 3: Diagrams (page 1 of 3)

The diagrams, below, are taken directly out of Environment Agency’s Technical Guidance Note M1 (Monitoring) and BS EN 15259, and provide guidance on the space required behind the installed access ports, and therefore provide help on how to site the sample ports, relative to the installed access platform.

Plan view for typical small, vertical circular waste duct (< 3.6m diameter)

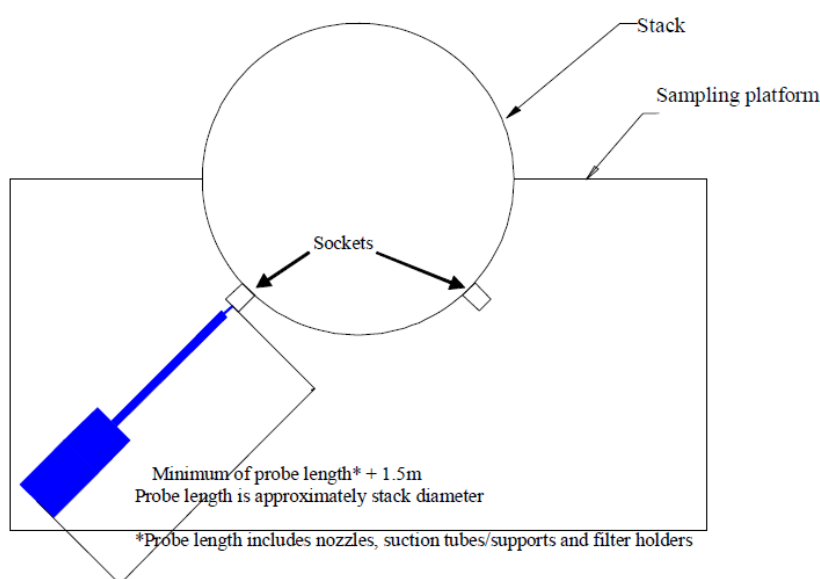

Plan view for typical vertical rectangular / square waste duct

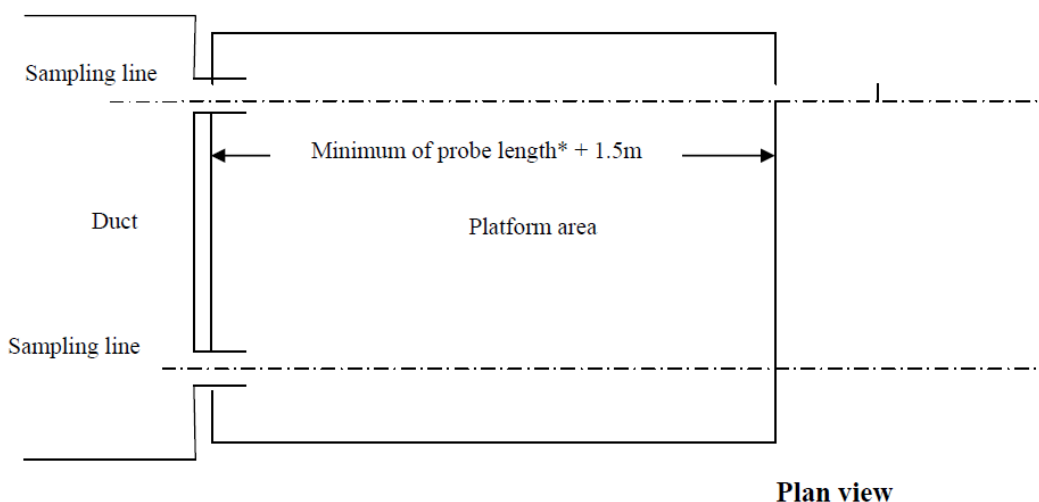

*the probe length includes nozzles, suction/support tubes and associated filter housing

APPENDIX 3: Diagrams (page 2 of 3)

Plan and Side Views of a large vertical circular waste duct (> 3.6m)

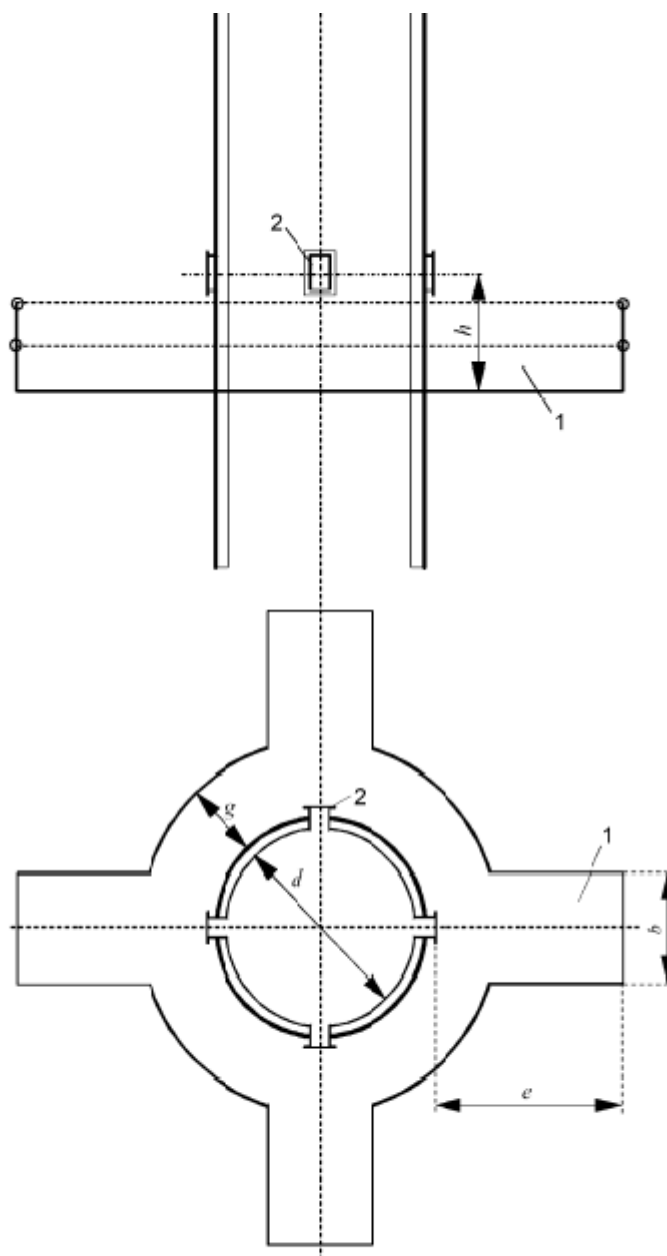

Key

- | | | | |
|---|------------------|-----|---|
| 1 | working platform | b | width of the working area |
| 2 | measurement port | d | internal diameter of the waste gas duct |
| | | e | depth of the working area |

APPENDIX 3: Diagrams (page 3 of 3)

Side View of a vertical rectangular waste duct

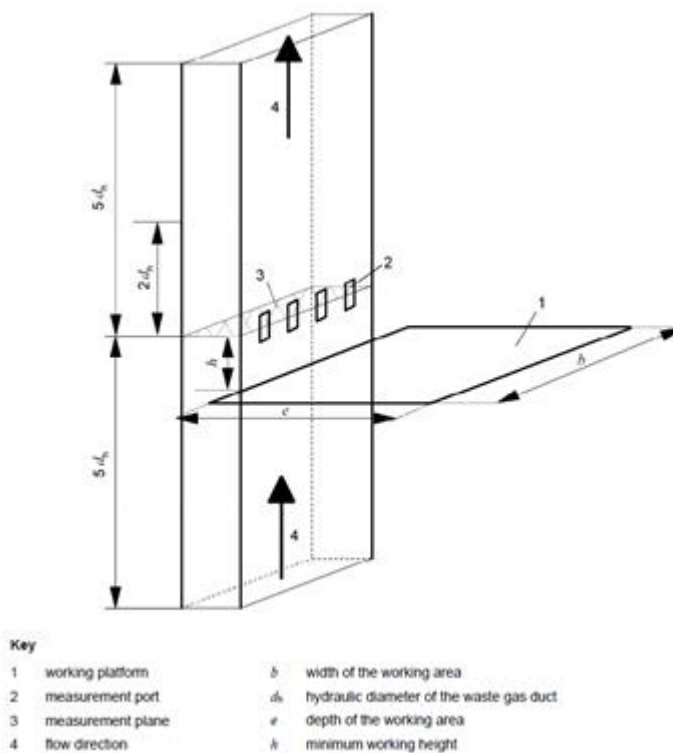

Side View of a horizontal rectangular waste duct

